

# forwa 2000

Matten-Produkte | RUWA Anschluss-Systeme

Matten-Produkte

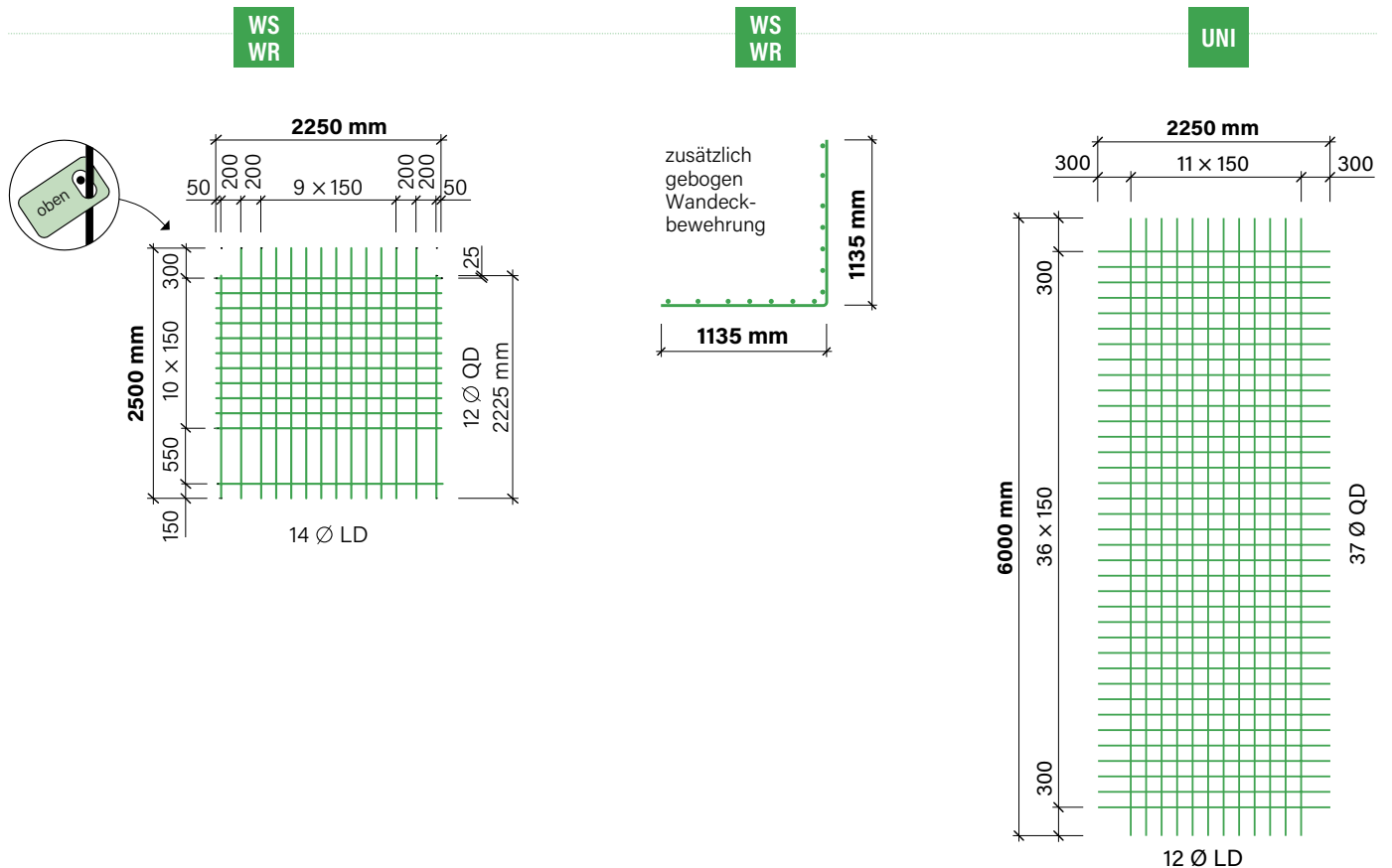
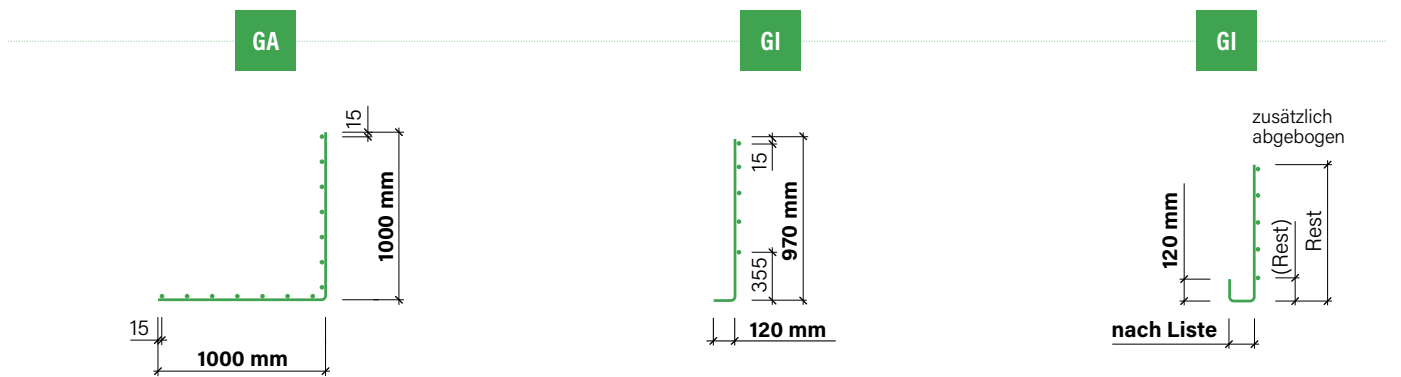
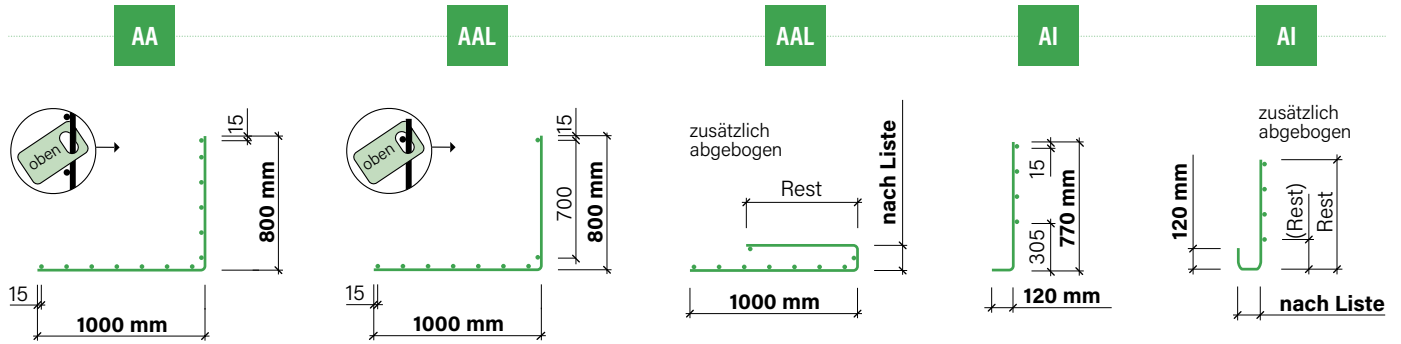

# forwa 2000

Matten-Produkte | RUWA Anschluss-Systeme

Format L × B [m]	Typ	Teilung		Durchmesser		Querschnitt a <sub>s</sub>		Gewicht		
		längs [mm]	quer [mm]	LD [mm]	QD [mm]	längs [mm <sup>2</sup> /m]	quer [mm <sup>2</sup> /m]	Matte [kg]	m <sup>2</sup> [kg/m <sup>2</sup> ]	lfm [kg/m]

## Anschluss aussen, Anschluss aussen leicht und Anschluss innen aus Betonstahl B500A

5.00	AA 250	150	150	7	7	257	257	36.3	4.08	7.26
5.00	AA 330	150	150	7	8	257	335	41.4	4.65	8.28
5.00	AA 420	150	150	8	9	335	424	53.2	5.98	10.64
5.00	AAL 330	150/700	150	7	8	(257)	335	35.4	3.98	7.08
5.00	AI 250	150	150	7	7	257	257	14.3	3.25	2.86
5.00	AI 330	150	150	8	8	335	335	18.7	4.24	3.74

Längsdraht-Überstände = 250 mm

## Grosser Anschluss aussen und grosser Anschluss innen aus Betonstahl B500A

5.00	GA 330	150	150	7	8	257	335	45.4	4.58	9.08
5.00	GA 420	150	150	8	9	335	424	58.3	5.89	11.66
5.00	GA 520	150	150	9	10	424	524	72.8	7.35	14.56
5.00	GI 330	150	150	8	8	335	335	23.1	4.27	4.62
5.00	GI 420	150	150	9	9	424	424	29.2	5.41	5.84

Längsdraht-Überstände = 250 mm

## Matten für Wandbewehrungen aus Betonstahl B500A

2.50 × 2.25	WS 250	150	150	7	7	257	257	18.6	3.30	-
2.50 × 2.25	WS 330	150	150	8	8	335	335	24.3	4.32	-
2.50 × 2.25	WR 420	150	150	7	9	257	424	23.9	4.25	-

## Flächenbewehrung universell aus Betonstahl B500A

6.00 × 2.25	UNI 330	150	150	8	8	335	335	61.4	4.54	-
6.00 × 2.25	UNI 420	150	150	9	9	424	424	77.5	5.74	-

Produktion nur auf Bestellung

